



TECHNICAL DATA SHEET

DOOR D – 311 CLEANROOM LF(*)

REF:D-311-CL LF

1. DESCRIPTION

Intended use: For inside environment.

Maximum dimensions: W 4.000 mm x H 4.000 mm.

Opening speed: 1,2 m/s. **Closing speed:** 0,5 m/s.

Mode of operation: gravity driven, with flexible weighted soft bottom edge.

Frame: made out of galvanised steel plate 37x52x3 mm. Optionally in stainless steel.

Drum: made of steel, diameter 102x2 mm, steel shafts. (drum and axes in stainless steel: see options).

Covers: drum cover, posts cover and motor cover in galvanised steel of 1,5mm standard.

Side guides made out of reinforced polyethylene (PE-UHMW/DYNACO Specific) mounted in a 1,25 mm thick galvanised steel C-profile, 11,5x11,3 mm inner section. Optionally in stainless steel. The C-profiles are fixed at the base of the structural channels with closed nuts, without springs.

Reinforced seal: the upper part is sealed by means of the curtain that presses against the bottom edge of the drum cover; to optimise the seal between the upper and lateral part of the door covers and the lintel, a peripheral joint has to be installed between them during installation of the door.

Door curtain in reinforced PVC (900 g/m²), very resistant. Available in following standard colours (RAL): yellow (1003), grey (7035), blue (5002), red (3000), green (6005), orange (2004), white (9010) or black (9005). The ends of the bottom bag, in which is situated the ballast, are closed to avoid the deposition of impurities.

Compact reintroduction block installed at the upper part of the side guide, made of PBT. Equipped with two reintroduction bearings (DYNACO Patent) to ensure automatic repair of the door.

Continuous side sealing (DYNACO Patent) made out of polyurethane (BEAD) (PUR-1195 degree shore A), extended to the floor.

Motor, 2-pole, without brake, controlled by a frequency inverter. Power: 0,75 kW. Voltage: 3 x 230/400 V. IP 65 protection level.

Limit switch: by means of an absolute encoder mounted onto the back of the motor.

Gearbox size 50. The reduction ratio 1/28 allows the static irreversibility of the reducer to maintain door position at all times.

Compact control box in painted steel, with a circuit breaker, pad-lockable divider, an adjustable timer for closing, a push button for opening and reset after a power failure or an emergency stop. IP 54 protection level. The length of the electrical cables for connecting the electrical components (motor and other standard elements) allows installation of the control box at 1200mm from the floor and 1000mm from the door at the motor side.

Detectors delivered with a standard door:

Infrared photocell system: installed ± 30 mm of the axis of the curtain and detecting the presence of a pedestrian or a vehicle, immediately opens the door and keeps it open as long as the presence is detected. Position of the photocell: 300 mm above the floor.

Correct unwinding detector: installed on the sealing strut, detecting the formation of curtain loops at the winding drum when an obstacle appears in the curtain's path, preventing its normal closing. This detector also opens the door.

Wireless DYNACO Detector (WDD): a wireless detection system consisting of a transmitter in the bottom bag of the door and a receiver in the control box. The system operates according to the "open loop" principle: when the sensor encounters an obstacle, the transmitter leaves the standby mode and sends a signal to the receiver that immediately opens the door. The operating mode "open loop" offers an extremely high life time to the lithium battery of the transmitter, as it only operates when the sensor encounters an obstacle, otherwise, the transmitter remains inactive.

Power supply: Single phase 220-240 V.

Frequency: 50 – 60 Hz. Circuit protection to be provided by the customer 16 A.

2. EN 13241-1 CLASSIFICATION

Characteristics	Standard	Test acc.	Results
Water permeability	EN 12425	EN 12489	Class 2
Wind load	EN 12424	EN 12444	Class 1*
Wind permeability	EN 12426	EN 12427	Class 2
Safe openings	EN 12453	EN 12445	Pass
Mechanical resistance	EN 12604	EN 12605	Pass
Unintended movements	EN 12604	EN 12605	Pass
Thermal resistance	EN 12428	EN 12428	6,02 w/m ² K
Performance (cycles)	EN 12604	EN 12605	1.000.000
* Indicated wind-load classification is for maximum dimension. For doors up to W3000mmxH3500: class 2			

3. SPACE REQUIREMENTS: All indicated dimensions are based on exact width and height dimensions only.

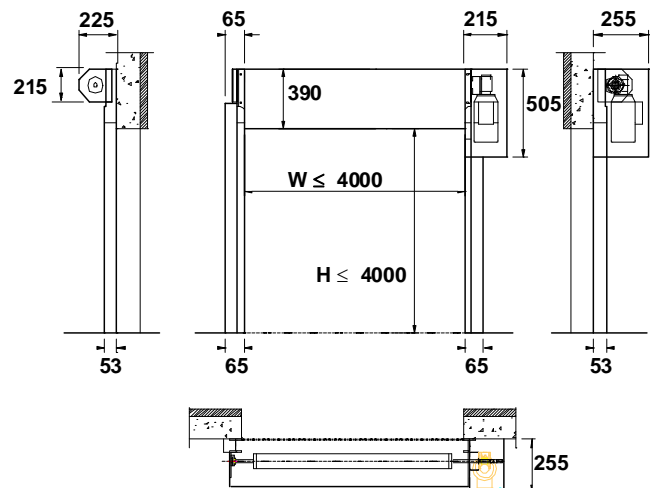

(*) LF = Dynaco LOW FRICTION System

Within the framework of its policy of continuous development of its products, DYNACO preserves the right to modify the characteristics of its products and parts without prior notice. Limits of use: see general sales conditions. Special product orders are available upon request.